

Operating instructions

EN **Automatic insulation stripper**
for stripping finely stranded to solid round cables

12 62 180

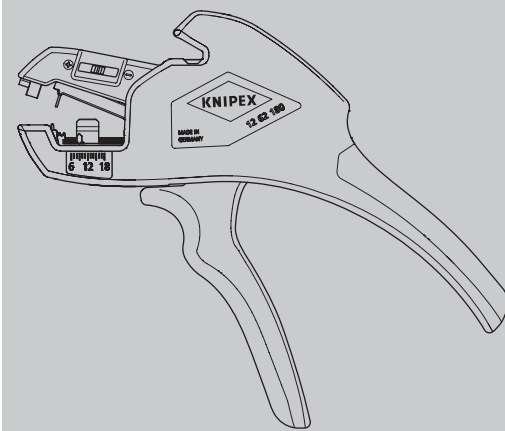

CONTENTS

1	General	3
1.1	Notes on operating instructions	3
1.2	Symbols used	3
1.3	Copyright	3
1.4	Guarantee and warranty	3
2	Safety	4
2.1	Intended use	4
3	Design and function	5
3.1	Design	5
3.2	Function	5
4	Operation	6
4.1	Cutting cables	6
4.2	Stripping cables (with single, multi and finely stranded conductors)	7
4.3	Fine adjustment of the cutting depth	8
5	Maintenance	9
5.1	Changing the length stop	9
5.2	Replacing the blades	10
6	Malfunction	12
6.1	Causes of malfunction and troubleshooting	12
7	Technical data	12
8	Disposal	12

1 General

1.1 Notes on operating instructions

These operating instructions are designed to enable you to use your tool safely and efficiently. The tool may only be used if it is in technically perfect condition. As a consequence of technical developments, the illustrations and descriptions contained in these operating instructions may differ slightly from the tool actually delivered. We do not accept any liability for damage caused by failure to observe these operating instructions.

1.2 Symbols used

All safety instructions in these operating instructions are indicated by corresponding symbols. The signal words at the beginning of each safety instruction express the extent of the Hazard.



Danger!

Level 1 risk source

This combination of symbol and signal word indicates an imminently hazardous situation that will result in death or serious injury if not avoided.



Warning!

Level 2 risk source

This combination of symbol and signal word indicates a possibly hazardous situation that may result in death or serious injury if not avoided.



Caution!

Level 3 risk source

This combination of symbol and signal word stands for important information that will assist in preventing damage to property or the environment.

1.3 Copyright

These operating instructions and all documentation supplied with this tool are protected by copyright and remain the property of KNIPEX. The reprinting of these instructions, even in extract form, is only permitted with the written consent of KNIPEX C. Gustav Putsch KG.

1.4 Guarantee and warranty

The manufacturer grants a statutory warranty in accordance with the current sales and delivery conditions. No further warranties or assurances are granted. Within the warranty period, the warranty covers the rectification of all defects that can be traced back to material faults or manufacturing errors. Wearing parts are excluded from the warranty. The repair or replacement of a tool shall not result in an extension of the warranty period. Tools shall only be repaired or replaced with "as new" parts, whose function corresponds to that of the old parts. All defective and hence replaced parts are the property of the manufacturer.

Warranty claims shall expire in particular if:

- Damage is caused through improper operation, use for purposes other than those specified by the manufacturer, or poor maintenance.
- Repairs or conversions are carried out by unauthorized persons.
- Original accessories or spare parts from KNIPEX are not used.
- Defective components are not repaired immediately to minimise the extent of the damage and so as not to impair the safety of the tool (obligation to repair).

For the rest, reference is made to the liability and warranty regulations of the current sales and delivery conditions.

In view of the wide variety of possible insulation materials with different properties, such as material hardness and material thickness, it is not possible to guarantee perfect stripping results in every application.

It is therefore the responsibility of the user to independently check the suitability and selection of the appropriate tool for the specific requirements. We are happy to offer advice and support on request.

2 Safety

2.1 Intended use

The tool is intended for the following uses:

- Stripping single, multi and finely stranded conductors from 0.2 to 6 mm²/AWG 24–10
- Cutting copper and aluminium conductors up to max. 2.5 mm² (solid) and 6 mm² (finely stranded)

The tool must **not** be used for the following applications:

- Cutting steel

Any use beyond the intended purpose or any unauthorized modification shall be considered improper. The operator shall be liable for damages resulting from improper use.

Intended use also includes adhering to these operating instructions. They must be read in full before use.



Warning!

Warning: Sharp blades!

Handling sharp blades is dangerous. For this reason, make sure to handle your tools with care when working.

3 Design and function

3.1 Design

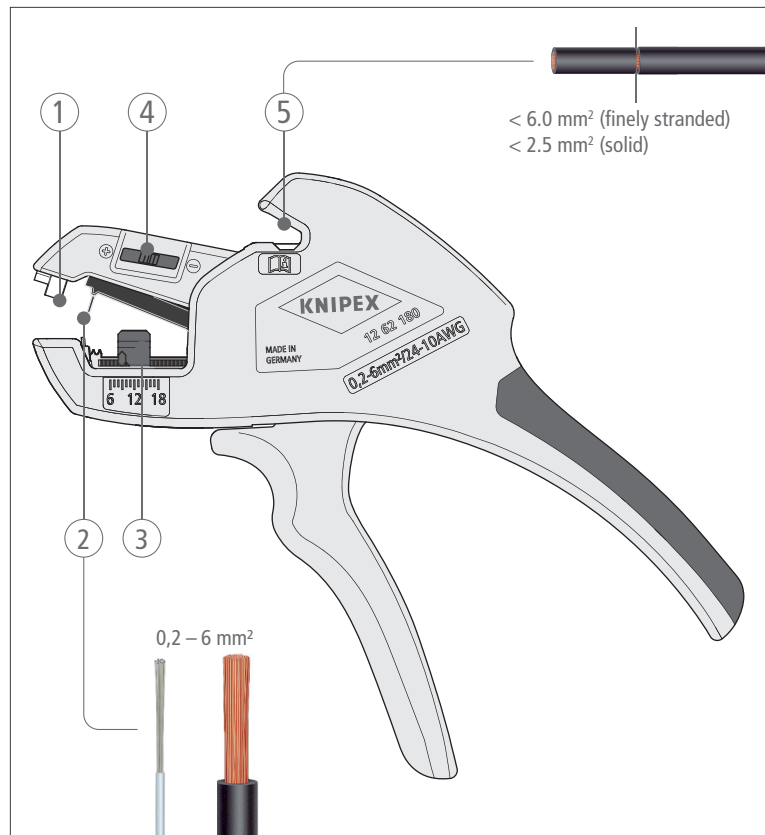

Design of the stripping tool

- 1 Holder for cables / conductors
- 2 Cutter for stripping
- 3 Adjustable length stop (6–18 mm)
- 4 Fine adjustment of the blade cutting depth to special materials or temperature conditions
- 5 Cable cutter for copper and aluminium conductors
max. 6 mm² (finely stranded), max. 2.5 mm² (solid)

3.2 Function

Solid, stranded and finely stranded conductors are shortened and stripped with the automatic insulation stripper.

4 Operation

4.1 Cutting cables

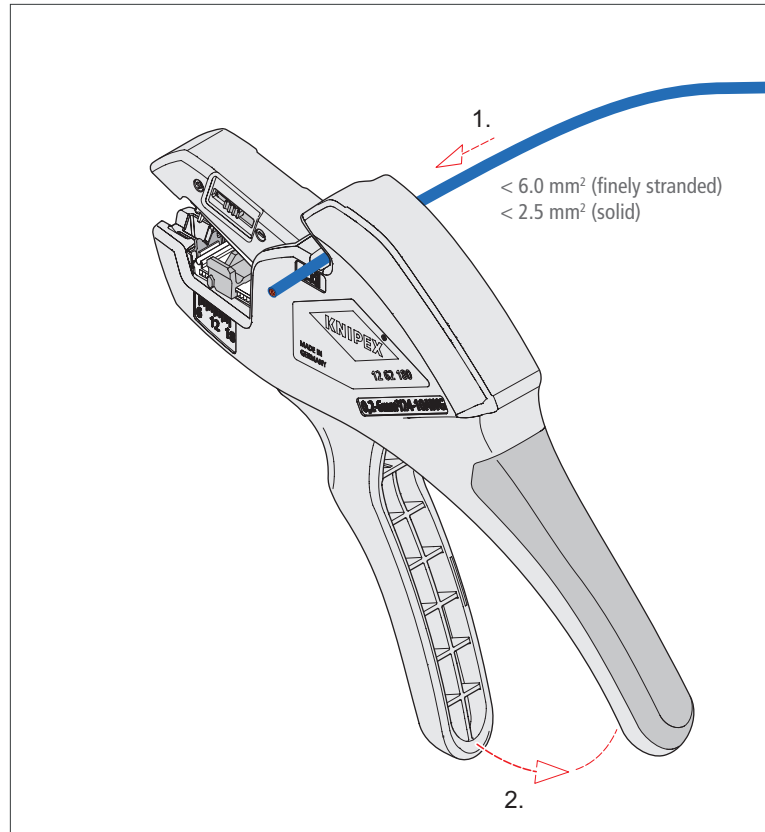

Cutting cables

1. Insert the end of the cable to be shortened between the two blades of the cable cutter.
2. Firmly press the two handles together.

4.2 Stripping cables (with single, multi and finely stranded conductors)

- » Set the length stop to the required length (6 to 18 mm). If you remove the length stop, you can strip a maximum length of 25 mm.
- » Insert the end of the cable into the holder.
- » Firmly press the two handles together.

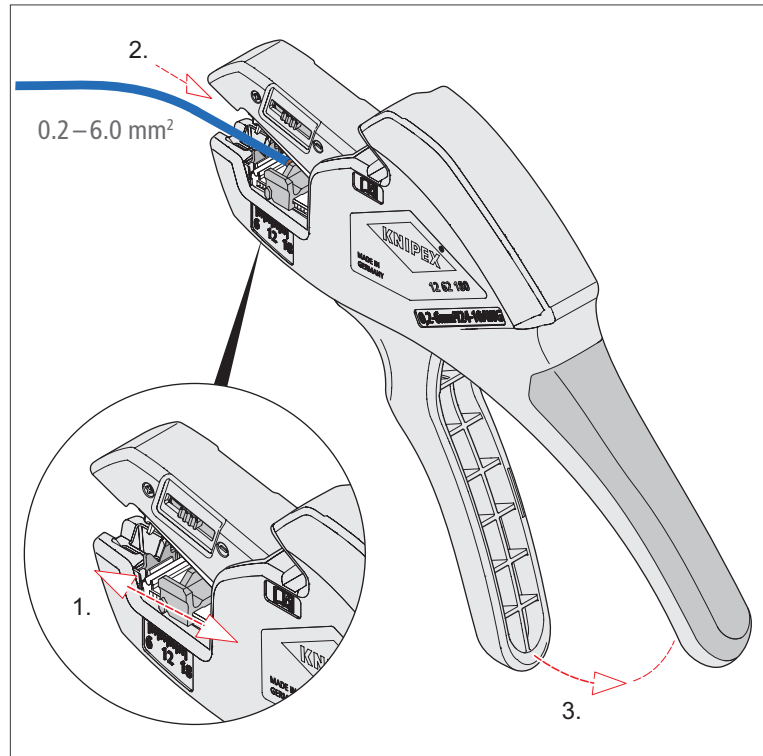

Stripping single conductors

- » Pull the stripped cable out of the holder.

4.3 Fine adjustment of the cutting depth

With special materials or temperature conditions, it may be necessary to readjust the cutting depth.

- » To do this, move the fine-adjustment slider towards "+" (increase cutting depth) or "-" (reduce cutting depth).

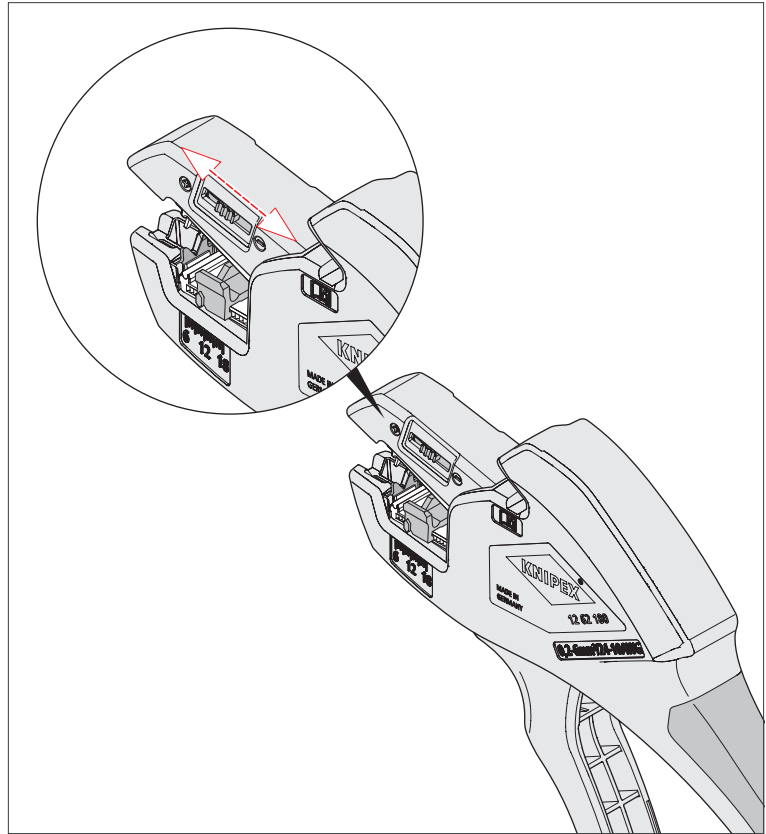

Readjusting the cutting depth

- » Perform a stripping test after each readjustment.
- » Keep moving the slider until the desired stripping result has been achieved.

5 Maintenance

Tip:

To increase the service life of the pliers, oil the moving parts and the opening spring regularly.

Use low-viscosity maintenance oils for this (e.g. oils for sewing machines or bicycles).

5.1 Changing the length stop

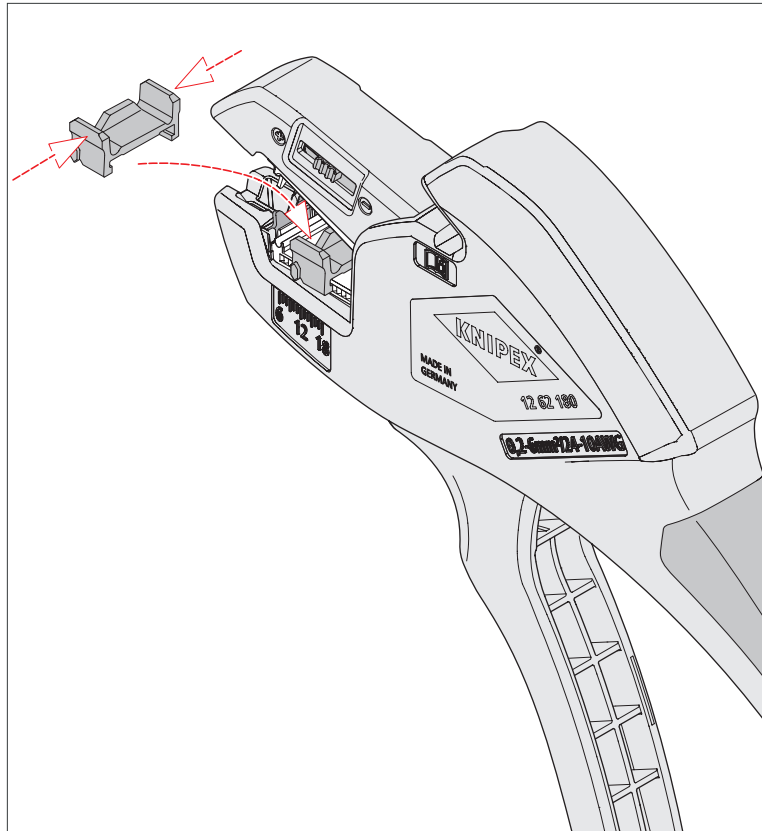

Replacing the length stop

1. Press the length stop together lightly and pull it off the guide.
2. Place the new length stop onto the guide and gently press it together until it clicks into place.
3. Check whether the length stop can be moved.

5.2 Replacing the blades

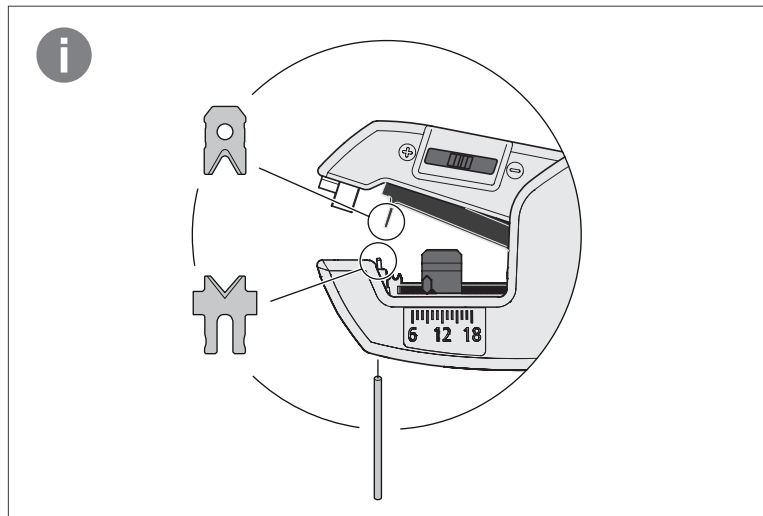

Installation info

5.2.1 Changing the upper blade

1. Press down on the top of the blade unit to access the screw on the front of the top blade. If necessary, use a small screwdriver to press down on the top of the blade unit.
2. Remove the screw using a TX8 screwdriver and remove the worn blade.

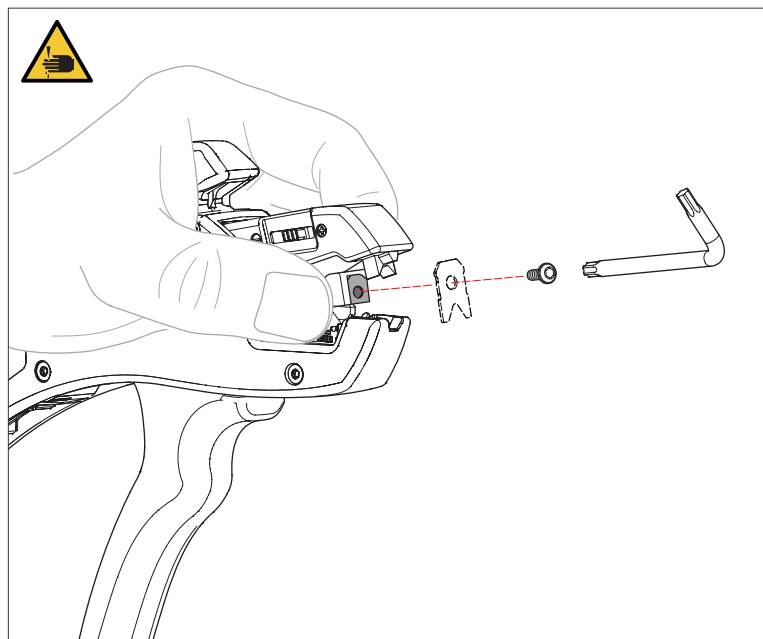

Removing the upper blade

3. Insert the new blade in same place and screw it tight.

Note:

Pay attention to the correct position. The partially ground cutting edges of the blade must point inwards (into the tool).

5.2.2 Changing the lower blade

1. Use the metal pin provided to slide the bottom blade out from below.

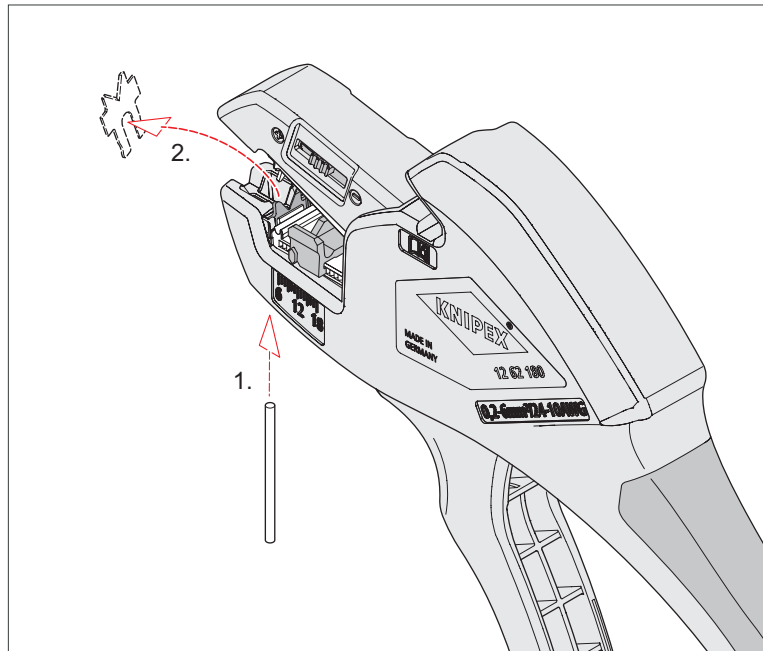

Removing the bottom blade

2. Use flat nose pliers to push the new blade in at the same position from above. If necessary, press down a little with the pliers.

Note:

Pay attention to the correct position. The ground cutting edges of the blade must point outwards (away from the tool).

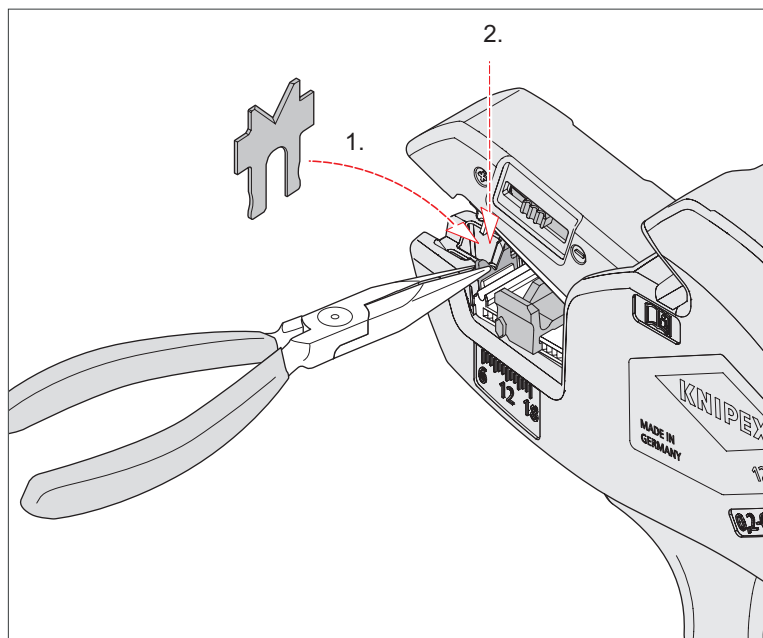

Installing the bottom blade

3. Dispose of the used blades properly.
4. Check that the insulation stripper is working correctly by stripping a cable.

6 Malfunction

6.1 Causes of malfunction and troubleshooting

The following table provides an overview of the most common faults:

Error	Cause	Remedy
Blades slide over the insulation	The cutting depth of the stripping knives is not set correctly	Use the slider to set the cutting depth of the stripping blades. To do this, refer to point 4.3 of this operating manual.
	The knives are worn	Replace the blade unit (spare part item no.: 12 69 21)
Stripping result not acceptable	This pliers is not suitable for the cable's insulation material (e.g. multi-layered solar cable or rubber cable)	Use another pliers from the KNIPEX range
	The knives are worn	Replace the blade unit (spare part item no.: 12 69 21)

7 Technical data

Technical data	Unit	
Part number pliers	–	12 62 180
Part number spare blade	–	12 69 21
Part number spare length stop	–	12 69 23
Length	mm	180
Weight	g	151
Housing material	–	glass fibre reinforced plastic
Blade material	–	special tool steel, oil-hardened
Stripping capacity	mm ²	0.2–6.0
Stripping capacity	AWG	24–10
Cutting capacity	mm ²	max. 6 for finely stranded cables, max. 2.5 for solid cables

8 Disposal

The tool can be disposed of as household waste.



KNIPEX-Werk
C. Gustav Putsch KG

42337 Wuppertal

Tel.: +49 202 – 47 94-0
Fax: +49 202 – 47 74 94

info@knipex.com
www.knipex.com