

**HEWI**

# Emergency door fittings Reliable Safety

EN 1125 | EN 179



# Fittings for escape and rescue routes

When designing and equipping public buildings, the safety of people is paramount. Escape routes must be intuitive and escape doors easy to open, especially in dangerous situations. Reliable and long-lasting hardware solutions must facilitate swift escape in the event of an emergency.

To achieve this, the emergency exits must be easy to open using a handle and without the user having any prior knowledge. HEWI panic bars and handles can be operated intuitively with minimal effort and meet all requirements for escape and rescue routes.

Lever handles are used at emergency exits where a panic situation is not to be expected because the people in the building are familiar with the exits (DIN EN 179). Panic bars, on the other hand, are used at emergency exits where panic situations can arise as people are not familiar with the exits and fittings (DIN EN 1125).



HEWI certified emergency exit fittings are marked with this symbol:



- **Minimised mechanics** – narrow gear unit
- **Intuitive operability** – double grip surface indicates the optimum operating zone
- **Clamp-free for double leaf doors** – due to narrow housing and inner bar
- **Telescopic panic bar** – simplifies precise fitting



## Two-senses principle

- High-contrast design of the gripping area facilitates orientation in the building for people with impaired vision
- According to DIN 18040, at least two senses (seeing, hearing or feeling) should be addressed simultaneously (compensation for missing or limited perception via another sense)
- HEWI panic bars communicate operation via two senses
- Double handle section made of coloured polyamide (available in HEWI colours signal white, pure white, anthracite grey, deep black, ruby red and meadow green) indicates operation and also makes it tactilely detectable
- Door opens when pressure is applied against the horizontal operating bar



## Polyamide colours



98 Signal white



99 Pure white



92 Anthracite grey



90 Deep black

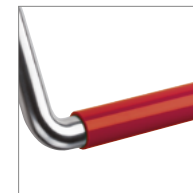

33 Ruby red

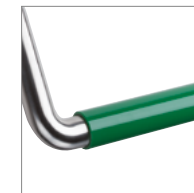



73 Meadow green



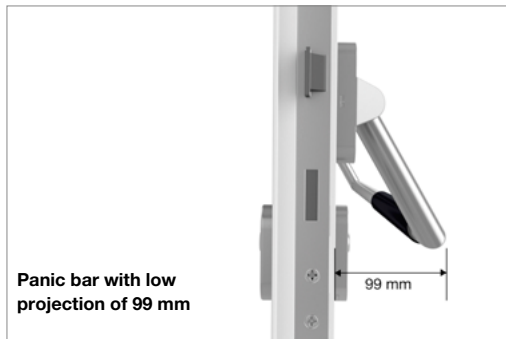

# EN 1125 Panic bar | Range

- Made of high quality stainless steel or powder-coated with a matt black finish for more security design options
- Double gripping surface made of polyamide, stainless steel or powder-coated in matt black visualises the optimum operating range and facilitates intuitive use
- Suitable for escape and rescue routes according to EN 1125
- Intuitive operation with minimal effort
- Slim design due to minimised mechanics with narrow gear unit
- Collision of door frame and panic bar is prevented thanks to the narrow gearbox and the positioning of the bar on the inside of the gearbox



**Panic bar system 111 | according to EN 1125**  
**NEW in black deep matt**  
 PS111XA2060 DC  
 PS111XA4060 DC (BKS)  

**Panic bar system 162 | according to EN 1125**  
**NEW in black deep matt**  
 PS160XA2060 DC  
 PS160XA4060 DC (BKS)  

**Panic bar system 111 | according to EN 1125**  
 PS111XA10\* Polyamide gripping surface  
 PS111XA30\* (BKS)  
 \*Polyamide colours        

**Panic bar system 162 | according to EN 1125**  
 PS160XA10\* Polyamide gripping surface  
 PS160XA30\* (BKS)  
 \*Polyamide colours        

**Panic bar system 111 | according to EN 1125**  
 made of stainless steel, satin finish  
 PS111XA20  
 PS111XA40 (BKS)  

**Panic bar system 162 | according to EN 1125**  
 made of stainless steel, satin finish  
 PS160XA20  
 PS160XA40 (BKS)  





## Telescopic capability

Precise installation particularly easy due to the telescopic nature (710 - 1580 mm) of the panic bar. This allows the panic bar to be easily adjusted to the desired mounting width. 12 scale sizes facilitate length adjustment. This eliminates the need for subsequent finishing work on the construction site.

## Mounting distance (MD)

telescopic from	436 to	485 mm
telescopic from	486 to	535 mm
telescopic from	536 to	585 mm
telescopic from	586 to	635 mm
telescopic from	636 to	685 mm
telescopic from	686 to	760 mm
telescopic from	761 to	860 mm
telescopic from	861 to	1010 mm
telescopic from	1011 to	1160 mm
telescopic from	1161 to	1300 mm
telescopic from	1301 to	1440 mm
telescopic from	1441 to	1580 mm

Learn more about this in the film:



**Please click here to see the certified lock manufacturers.**

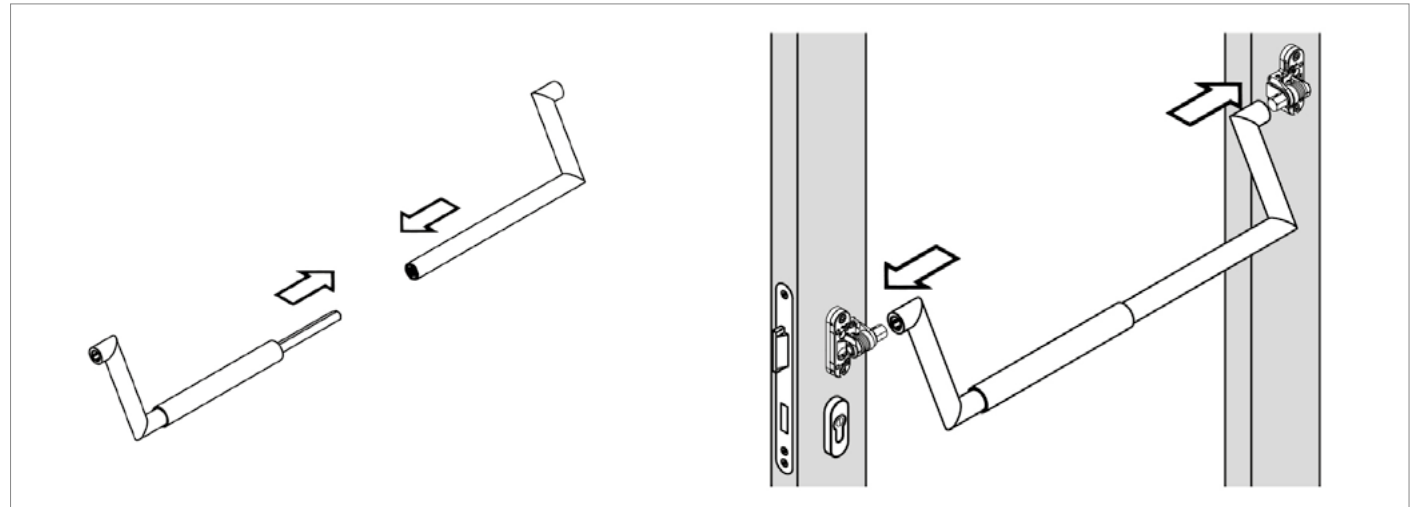

## Certified lock manufacturers

To meet the requirements of EN 1125, the panic bar may only be used with jointly tested and certified locks.

- Certified lock manufacturers: BKS (PS111XA30 | PS111XA40 | PS160XA30 | PS160XA40 | PS111XA4060 | PS160XA4060)
- Certified lock manufacturers: Assa Abloy, BMH, Fuhr, GEZE, Grundmann, KfV, eff eff, DOM or Wilka (PS111XA10 | PS111XA20 | PS160XA10 | PS160XA20 | PS111XA2060 | PS160XA2060)

Information on the classification of the panic bar according to EN 1125 can be found in the certificates of the respective lock manufacturer.

**ASSA ABLOY**



GRUNDMANN



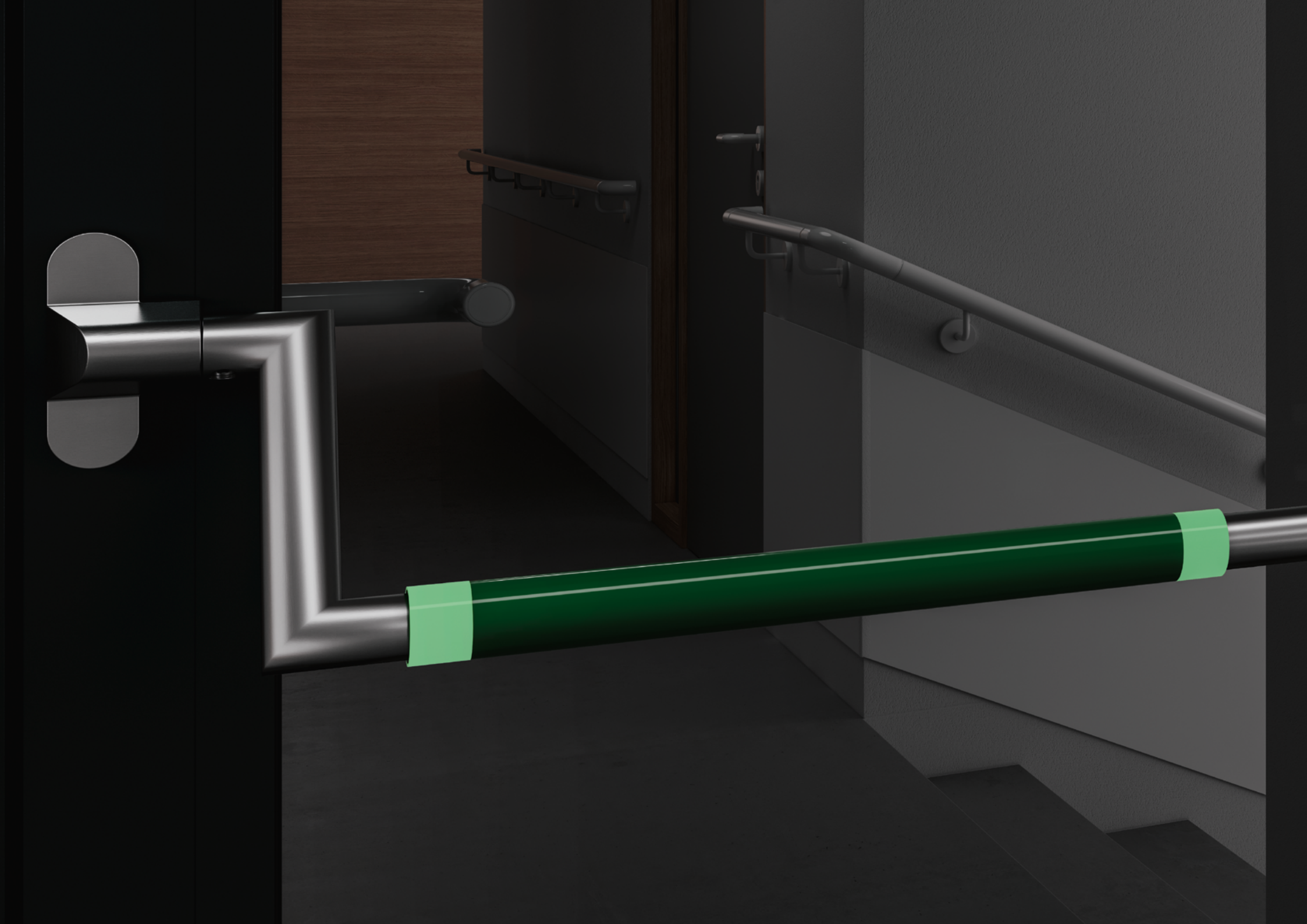

# Panic bar EN 1125 | Glow

## Direction sign in the dark

The luminescent elements of the panic bar glow indicate the way out even in the dark. Fluorescent pigments store ambient light allowing them to glow in the dark. The panic bar glow works without the need for a power supply and increases safety and guidance along escape and rescue routes thanks to its fluorescent elements.

See more about this in the film:

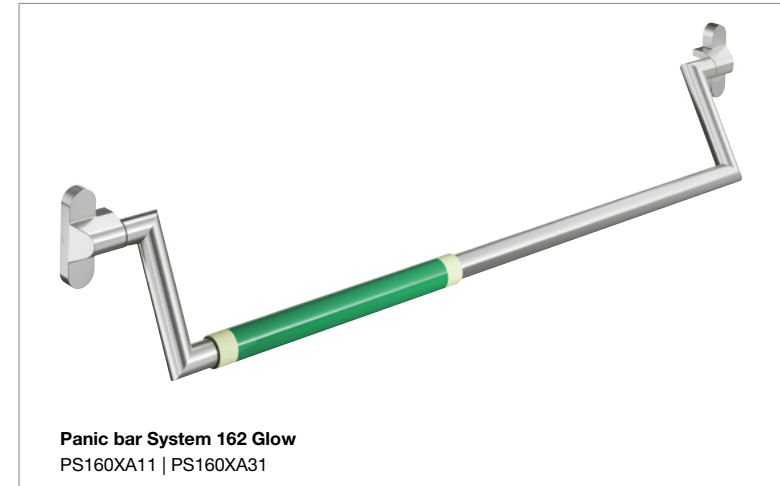



## Counter fittings for panic bars PS111X and PS160X

To meet the requirements of EN 1125, the panic bar may only be used with jointly tested and certified locks.

Matching stainless steel or powder coated (deep matt black) finishes are available for the panic bar models, ensuring a consistent-look within the architecture.

## Counter fittings for panic bar attachment

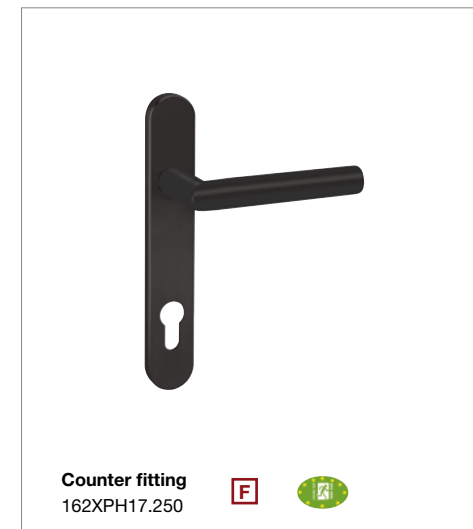
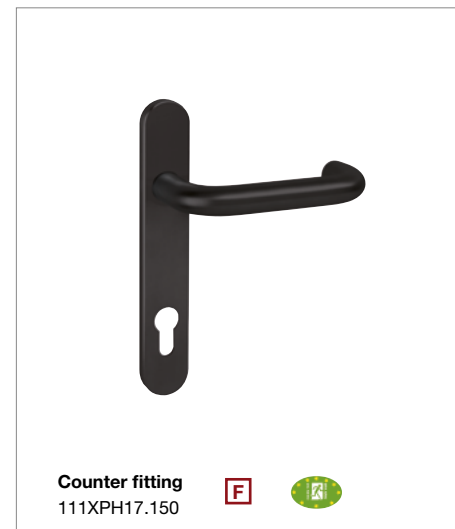
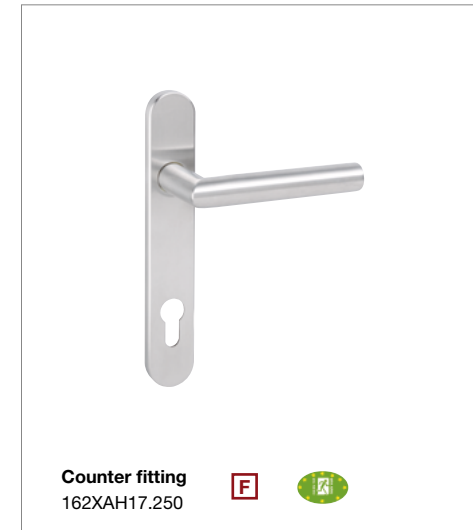
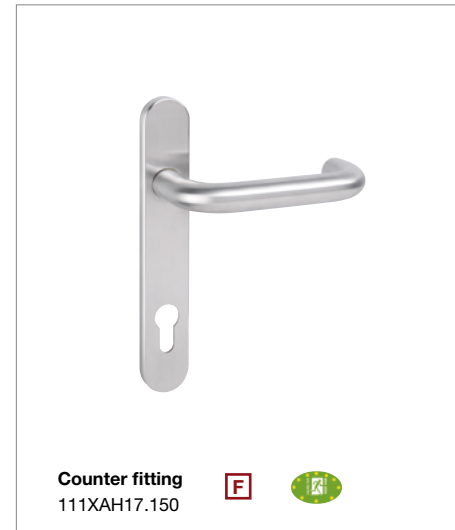
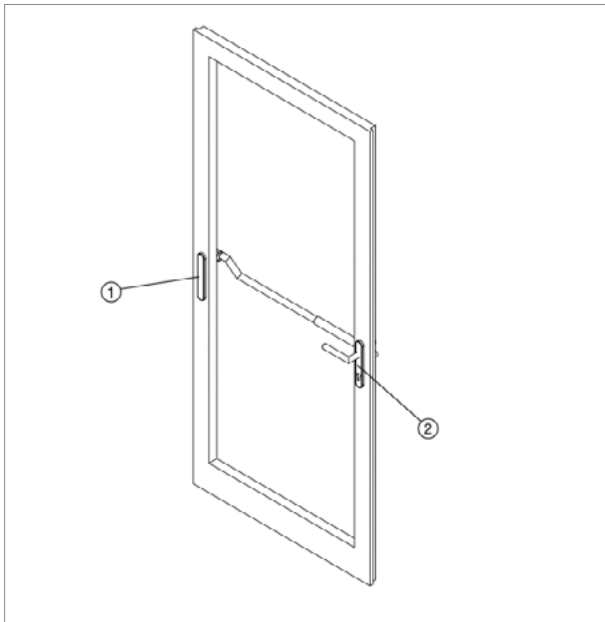

**Functional fittings**  
Stainless steel | powder-coated stainless steel

XA matt ground
  XP Deep matt black powder-coated



DRÜCKEN

## Accessible escape route solutions

Lever handles can be used at emergency exits where panic is unlikely because people in the building are familiar with the exits.

HEWI lever handles meet the requirements for emergency exits in accordance with EN 179 in combination with tested lock systems.

- Particularly suitable for heavy doors, as the lever handle reduces the effort required to open the door.
- Lever handles enable accessibility at a variable height of 75 to 120 cm (according to DIN 18040, a height of 85 cm is recommended for wheelchair users or small children).
- Flexible gripping height of the lever handle enables high operating comfort – even for tall people and walker users.
- For emergency exits: authorization acc. to EN 179 only in combination with tested lock systems. Information on the classification of the handle according to EN 179 can be found in the certificates of the respective lock manufacturer.
- For fire doors in Germany: Installation in a smoke and fire door only possible with valid national usability certificate.

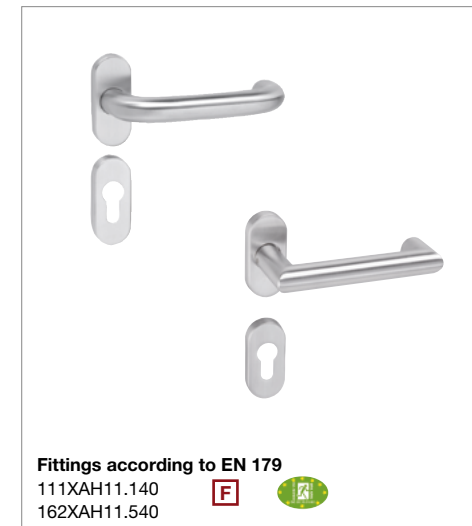
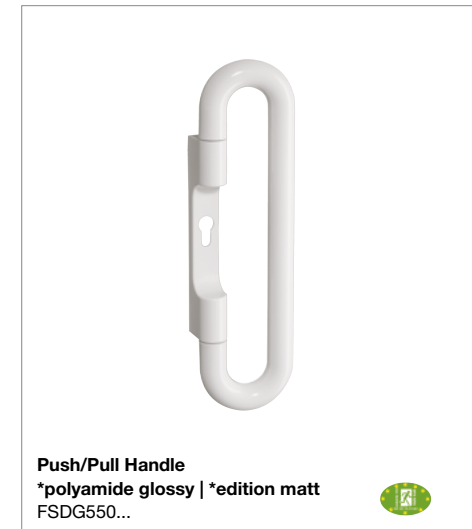

Please click here to see the certified lock manufacturers.



# HEWI

**Germany**

HEWI Heinrich Wilke GmbH

PO Box 1260

34442 Bad Arolsen

Phone: +49 5691 82-0

Fax: +49 5691 82-319

[info@hewi.de](mailto:info@hewi.de)